

# OPERATION & ASSEMBLY INSTRUCTIONS

# SUN | DASH



## *XXS 35 Seashell*

# Specifications

Length: 85"  
 Width: 41"  
 Height: 39.8" - 49.6"  
 No. of Lamps: 32 Low Pressure & 1 High Pressure  
 Electrical: 120/208VAC and 120/240VAC  
 Circuit Required: 20 Amp Breaker

**DANGER - ULTRAVIOLET RADIATION.** FOLLOW INSTRUCTIONS. AVOID OVEREXPOSURE. AS WITH NATURAL SUNLIGHT, OVEREXPOSURE CAN CAUSE EYE AND SKIN INJURY AND ALLERGIC REACTIONS. REPEATED EXPOSURE MAY CAUSE PREMATURE AGING OF THE SKIN AND SKIN CANCER. WEAR PROTECTIVE EYEWEAR; FAILURE TO MAY RESULT IN SEVERE BURNS OR LONG-TERM INJURY TO EYES.

MEDICATIONS OR COSMETICS MAY INCREASE YOUR SENSITIVITY TO THE ULTRAVIOLET RADIATION. CONSULT PHYSICIAN BEFORE USING SUNLAMP IF YOU ARE USING MEDICATIONS OR HAVE A HISTORY OF SKIN PROBLEMS OR BELIEVE YOURSELF ESPECIALLY SENSITIVE TO SUNLIGHT. IF YOU DO NOT TAN IN THE SUN, YOU ARE UNLIKELY TO TAN FROM THE USE OF THIS PRODUCT.

THIS UNIT UTILIZES UVA LAMPS. REPLACE TOP UNIT ONLY WITH **GENESIS 120W HP 20, F71-T12-HO-BP-120W, GENESIS 120W HP 20, F59-T12-HO-BP-120W** AND FACIAL LAMPS WITH **JK RUSA 400W** AND BOTTOM UNIT WITH **GENESIS 120W HP 20, F71-T12-HO-BP-120W.**

LIE ON ACRYLIC SURFACE AND LOWER TOP SECTION. TOP SECTION WILL STOP AT 12 INCHES (305 MM) FROM BOTTOM ACRYLIC SURFACE. THE USE OF ANY OTHER POSITION MAY RESULT IN OVEREXPOSURE.

<b>Recommended Exposure Schedule</b>					
<b>Skin Type</b>	<b>Week 1</b>	<b>Week 2</b>	<b>Week 3</b>	<b>Week 4</b>	<b>Weekly</b>
	<b>1st - 3rd</b>	<b>4th - 6th</b>	<b>7th - 10th</b>	<b>11th - 15th</b>	<b>Subsequent</b>
	<b>Treatments</b>	<b>Treatments</b>	<b>Treatments</b>	<b>Treatments</b>	<b>Treatments</b>
<b>I - Sensitive</b>	<b>Not Advised</b>	<b>Not Advised</b>	<b>Not Advised</b>	<b>Not Advised</b>	<b>Not Advised</b>
<b>II - Fair</b>	<b>3 Min.</b>	<b>7 Min.</b>	<b>15 Min.</b>	<b>15 Min.</b>	<b>20 Min.</b>
<b>III - Average</b>	<b>3 Min.</b>	<b>7 Min.</b>	<b>15 Min.</b>	<b>15 Min.</b>	<b>20 Min.</b>
<b>IV - Brown</b>	<b>3 Min.</b>	<b>10 Min.</b>	<b>15 Min.</b>	<b>20 Min.</b>	<b>20 Min.</b>
<b>V - Dark Brown</b>	<b>3 Min.</b>	<b>10 Min.</b>	<b>15 Min.</b>	<b>20 Min.</b>	<b>20 Min.</b>

**MAXIMUM EXPOSURE TIME IS 20 MINUTES.**

TANNING CAN BEGIN ON A REGULAR BASIS. AN APPEARANCE OF TANNING NORMALLY APPEARS AFTER A FEW EXPOSURES AND MAXIMIZES AFTER FOUR (4) WEEKS OF EXPOSURE FOLLOWING THE RECOMMENDED SCHEDULE FOR YOUR SKIN TYPE.

USE PROTECTIVE EYEWEAR, WHENEVER THE EQUIPMENT IS ENERGIZED. READ THE INSTRUCTION BOOKLET BEFORE USING THIS UNIT.

**INSTRUCTIONS ACCOMPANYING THIS PRODUCT SHOULD ALWAYS BE FOLLOWED TO AVOID OR MINIMIZE POTENTIAL INJURY.**

"THIS PRODUCT IS IN CONFORMITY WITH PERFORMANCE STANDARDS FOR SUNLAMP PRODUCTS UNDER 21CFR PART 1040."

# Warnings and Cautions

Certain drugs - particularly those that produce photosensitivity - may cause individuals under the influence of this type drug to experience adverse effects and those people should avoid exposure to UV sources of all kinds. Doctors will advise persons taking these drugs to possible adverse effects.

It is recommended that only one person at a time should use the tanning system while in use, and advises using protective eyewear while taking a tanning session. One pair of goggles is provided with each sunbed sold.

## WARNING

If you have been diagnosed by a physician as being allergic to the sun or are currently taking photosensitive medications, consult your physician before using the tanning unit.

Occasionally, persons using the tanning system will experience a slight reddening of the skin - usually in small patches - after the second or third session. This redness is often accompanied by an itching sensation. This may be nothing more than a heat "rash" caused by heat from the lamps within the system.

It is generally very limited and caused by constant contact of the skin with the acrylic surface. It should go away within approximately 24 hours and should not reappear. This rash can be lessened or prevented by applying moisturizer lotion to the affected area after the tanning session is completed.

## CAUTION

While there is no immediate clinical evidence UVA exposure and its effects upon expectant mothers, it is strongly advised that expectant mothers be discouraged from using the tanning unit.

**WARNING** - Failing to properly maintain this equipment in accordance with the manufacturers instructions can result in a FIRE HAZARD where dirt or dust is allowed to accumulate. Failing to preform required testing, lubercating, or adjusting as recommended by the manufacturer can result in a failure of the equipment which MAY RESULT IN SERIOUS INJURY OR DEATH.

## Mandatory Reading

**Always read and follow all instructions for proper usage prior to using any tanning system.**

### Remember:

1. Follow the exposure schedule in accordance with your skin type. Failure to do so may result in overexposure.
2. A tanning system is not a toy. Children should not play on, around or use this tanning equipment. You cannot vary the strength of the lamps in your unit.

Should you have any questions regarding the proper use of your tanning system, contact JK Products and Services at:

**800-445-0624**  
**Monday - Friday**  
**7:00 a.m. to 7:00 p.m. (CST)**

# Care and Cleaning of Your Tanning Unit

After each session is completed, spray the acrylic surface with specially formulated UVT (ultraviolet transmitting) acrylic cleaner. Wipe the surface of the acrylic with a clean cloth. The acrylic should never be wiped with a dry

cloth because this will generate a slight static charge which will attract dust. A mild liquid detergent and water solution can be used temporarily in place of Acrylic Cleaner.

For maximum efficiency of your tanning unit, periodic cleaning of lamps, reflectors and the inside of the acrylics is required. Refer to relamping instructions for acrylic removal.

**CAUTION:** Do not use excessive amounts of water, any abrasive cleaners, or any spray cleaners that carry label warnings regarding reactions to contact with skin!

## Skin Types

**Melanin** - The brownish pigment produced by special cells in the base layer of your skin determines the individual's tan. As the skin is exposed to the ultraviolet light, the melanin is activated and combines with protein cells that rise to the skin's surface, thus producing a tan.

The amount of melanin in your body determines how quickly and dark you tan. The more melanin produced and exposure time an individual has, the faster and deeper the individual will tan.

Do not tan more than once in a twenty-four (24) hour period.

### NOTE

The tan produced by the tanning unit is a deep, rich "COSMETIC" tan. However, regardless of how dark an individual may tan on this system, it will not provide adequate protection against overexposure to natural sunlight or UVB tanning systems.

**Skin Type I** - Always burns, not advised to tan.

**Skin Type II** - This is the individual that usually burns easily and severely, tans minimally or lightly and peels.

**Skin Type III** - Often referred to as "AVERAGE" complexion, burns moderately and tans about average.

**Skin Type IV** - This individual burns minimally, tans easily and above average with each exposure.

**Skin Type V** - This individual's skin rarely burns, tans easily and substantially.

**NOTE:** No two individual skin tones are the same. A tan to one person may be different to another and treatment length may vary.

## PACKAGING

The tanning system is shipped in three separate boxes. The type of assembly in each box is labeled on the outside. The box containing the tanning system legs is placed on top, followed by the box containing the base and then the box containing the canopy. The tanning system should be unpacked and assembled in this order. For additional installation instructions consult the "ASSEMBLY" section of this manual.

### CONTENTS OF EACH BOX

#### LEG BOX:

- Two (2) legs
- Owner's manual
- Assembly hardware
  - **Canopy**
    - Four (4) 5/16 hex washer nuts, to secure canopy to the leg (PN 0022003209)
    - Four (4) 5/16 Nylock nut (PN 0022003249)
    - Four (4) ¼ flat washer (PN 0028003265)
  - **Base**
    - Four (4) ¼-20 HEX nuts used to secure the base to the legs (PN 0022003212)
    - Four (4) Flat ¼ washers used with above nuts
  - **Power Box**
    - Four (4) Phillips screws, to be used to secure "Power Box" to the legs and (PN 0024003092)
  - **Middle Façade**
    - Four (4) Philip screws used to secure middle façade to leg assembly (PN 0048003608)
  - **Front Façade**
    - Two Phillips truss-head ¼-20 screws used to secure front façade to the tanning system (PN 0020003041)

#### BASE BOX:

- Base of tanning system
- Power box
- Middle façade

#### CANOPY BOX:

- Top of tanning system
- Front façade

## FASTENER ILLUSTRATIONS

**5/16 Hex Washer Nut**



**1/4 - 20 Hex Nut**



**Phillips Screw #6 X 3/8**



**Flat Washer**

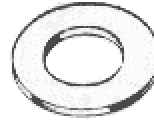

**Phillips Truss Head Screw 1/4 X 20**

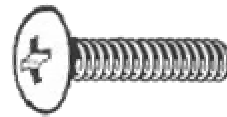

**CONTENTS**

**LEG**

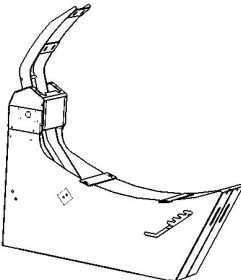

**POWER BOX**

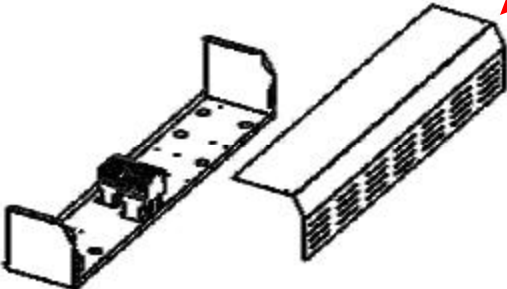

**POWER BOX COVER**

**MIDDLE FACADE**

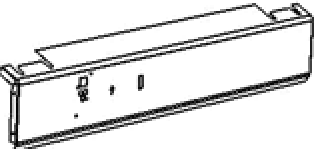

**FRONT FACADE**



**BASE**

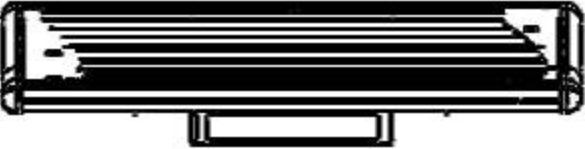

**CANOPY**



## ASSEMBLY

### ASSEMBLY

To avoid personal injury and or damage to the tanning system, it is recommended that the tanning system be assembled by a minimum of two persons.



**All electrical connections inside the tanning system should be completed by a Certified Electrician or a Factory Authorized Representative. Connection to electrical service should only be made by a Certified Electrician. All wiring and connections should conform to local and national electrical codes.**

To protect the tanning system components (acrylic, paint, etc.) from superficial damage during assembly or service, place a soft non-abrasive material over the tanning system and or over the area in proximity where the work is being performed.

### TOOLS REQUIRED FOR ASSEMBLY:

The following is a list of tools required for installation:

Standard screw driver ( - )



Phillips screw driver (+)  
Standard and Stubby

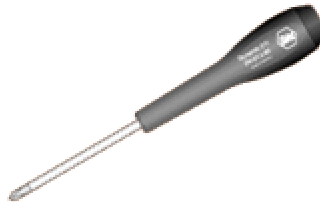

1/2" and 7/16" deep well socket  
and ratchet combination





## LEG INSTALLATION

1

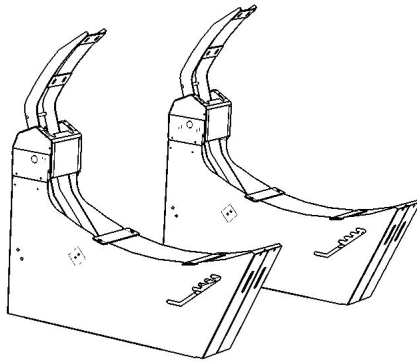

Remove packing and leg assemblies from the carton marked **LEG ASSEMBLIES**. Position leg assemblies in the desired location. The leg assemblies are in the shape of a boomerang and should face outward away from the wall with support brackets facing the middle. The legs should be approximately 2 ½ feet apart from each other and equal distance away from the wall (minimum 3"). (one person can handle the lifting and positioning of legs)

2

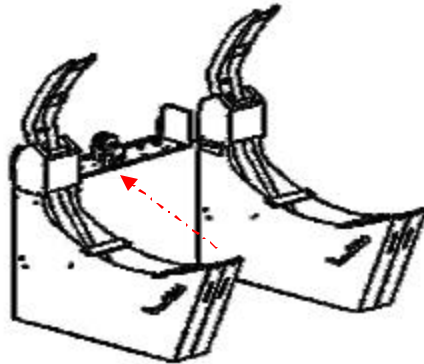

The "Power Box" should be installed next. The power box contains electrical components that receive and distribute power throughout the tanning system. The power box rests on the support brackets on each leg and is secured to the each leg assembly using #6 screws. This procedure will allow the legs to be properly positioned and ease the installation of the base and canopy (the installation of the "Power Box" can be completed by one person).

## BASE INSTALLATION

3

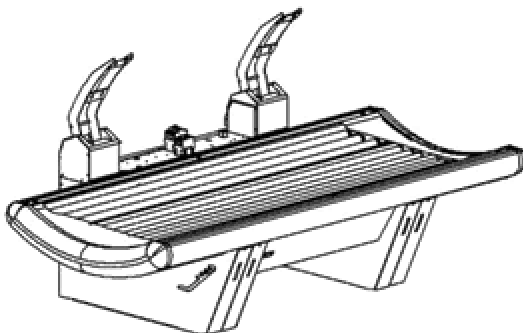

Remove packing and unit from box marked **BASE UNIT**. Lift base into position (acrylic facing up). The bolts should protrude the holes of the mounting bracket in the leg assemblies.

The base is secured to the leg assemblies using four (4) 1/4" nut and washer combinations (the "Base" can be easily installed by two individuals).

## CANOPY INSTALLATION

4

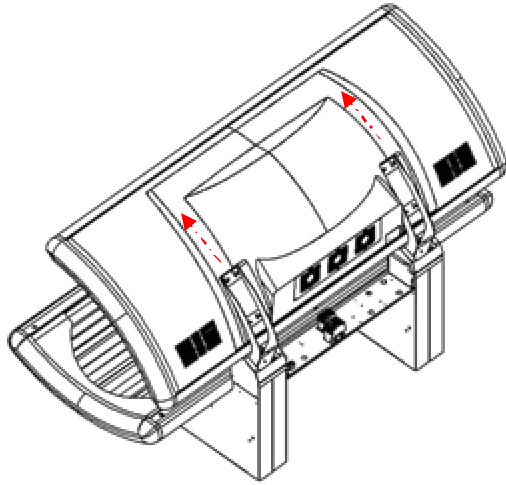

Remove packing and unit from box marked **TOP UNIT**. Lift top into position (acrylic facing down). The bolts should protrude through the holes of the mounting bracket in the leg assemblies. The canopy is secured to the leg assemblies using eight (8) 5/16" nuts (four on each leg).

Note: For proper balancing and limited spring adjustment of the canopy, the bolts of the canopy should rest against the top of the holes in the mounting bracket of the leg assembly. Ignoring this recommendation will allow the canopy to move to the closed position and not remain open (the canopy will require two individuals to install and secure into position. The addition of a third person will simplify the procedure of securing the "Canopy" to the legs).

## Bed Connections

### CANOPY AND BASE

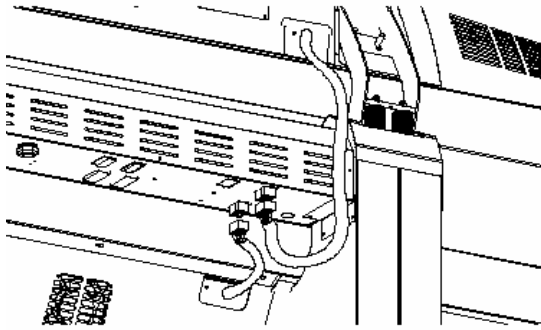

The power cords from the canopy and base are plugged into bottom of relay enclosure. The illustration to the left indicates the position of each wire.

### FACIAL

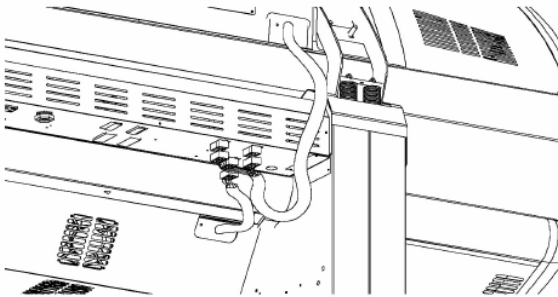

The power cord (on tanning systems with a facial lamp) for the facial assembly is equipped with plug. In 208V single/three-phase power configurations, a Buck-Boost transformer will be required. This tanning system cannot be configured to operate as three-phase. It can be installed in a three-phase panel using a two-pole breaker.

**Note:** The Buck-Boost transformer is required to boost power to the single facial lamp circuit. The Buck-Boost transformer should not be used to raise the operating voltage to the tanning system.



**ALL ELECTRICAL CONNECTIONS INSIDE OF TANNING SYSTEM MUST BE COMPLETED BY FACTORY AUTHORIZED PERSONNEL OR LICENSED ELECTRICIAN. CONNECTIONS TO THE ELECTRICAL SERVICE MUST BE COMPLETED BY LICENSED ELECTRICIAN ONLY.**

## BUCK-BOOST TRANSFORMER

**BUCK-BOOST TRANSFORMERS SHOULD NEVER BE USED TO BOOST POWER BEING SUPPLIED TO ENTIRE TANNING SYSTEM. POWER TO THE FACIAL TANNER CIRCUIT SHOULD ONLY BE BOOSTED WHEN REQUIRED (SEE EXPLANATION BELOW).**

The use of Buck-Boost transformers is NOT REQUIRED on units that do NOT have a facial tanner. A Buck-Boost transformer is not required for tanning systems with a facial tanner being installed in locations where the incoming power is 240V. A tanning system equipped with a facial tanner will require the use of a Buck-Boost transformer in locations where the incoming voltage to the salon is 208 volts.

A 0.15KVA transformer (JK Products PN #) boosting voltage from 208V to 230V supporting AMP load capacity of 7.0 AMPS is required to be used with the model having a facial tanner on 208V systems.

The Buck-Boost transformer should be installed on the right leg behind the tanning system (enough cable should be used when wiring the Buck Boost transformer to allow the tanning system to be moved a minimum of 24 inches away from the wall for service requirements). **All wiring and connections should conform to local and national electrical codes.**

The facial terminal block and facial relay are located on the power box. **CAUTION: To avoid personal injury and electrical shock hazard all electrical connections must be completed with the power to the tanning system off.**

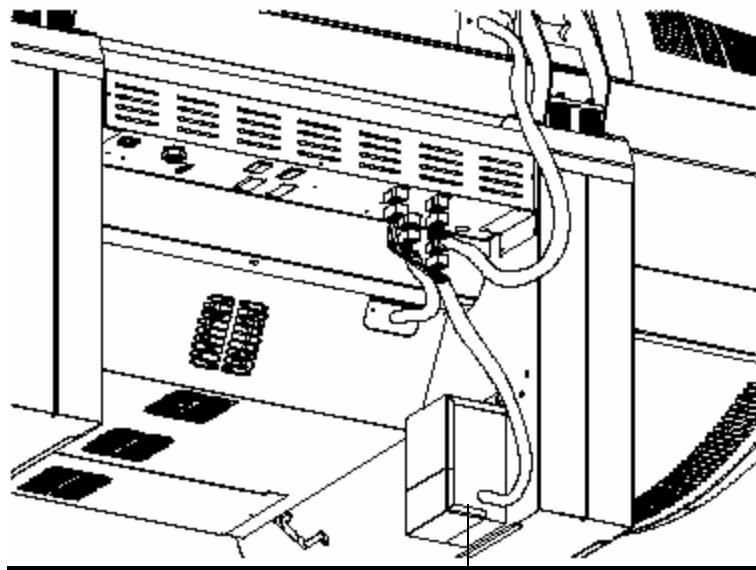

**Buck Boost Connection**

## WIRE CONNECTIONS

The illustration below shows the placement of each wire in the power box.

**ALL ELECTRICAL CONNECTIONS INSIDE OF TANNING SYSTEM MUST BE COMPLETED BY FACTORY AUTHORIZED PERSONNEL OR LICENSED ELECTRICIAN. CONNECTIONS TO THE ELECTRICAL SERVICE MUST BE COMPLETED BY LICENSED ELECTRICIANS ONLY.**

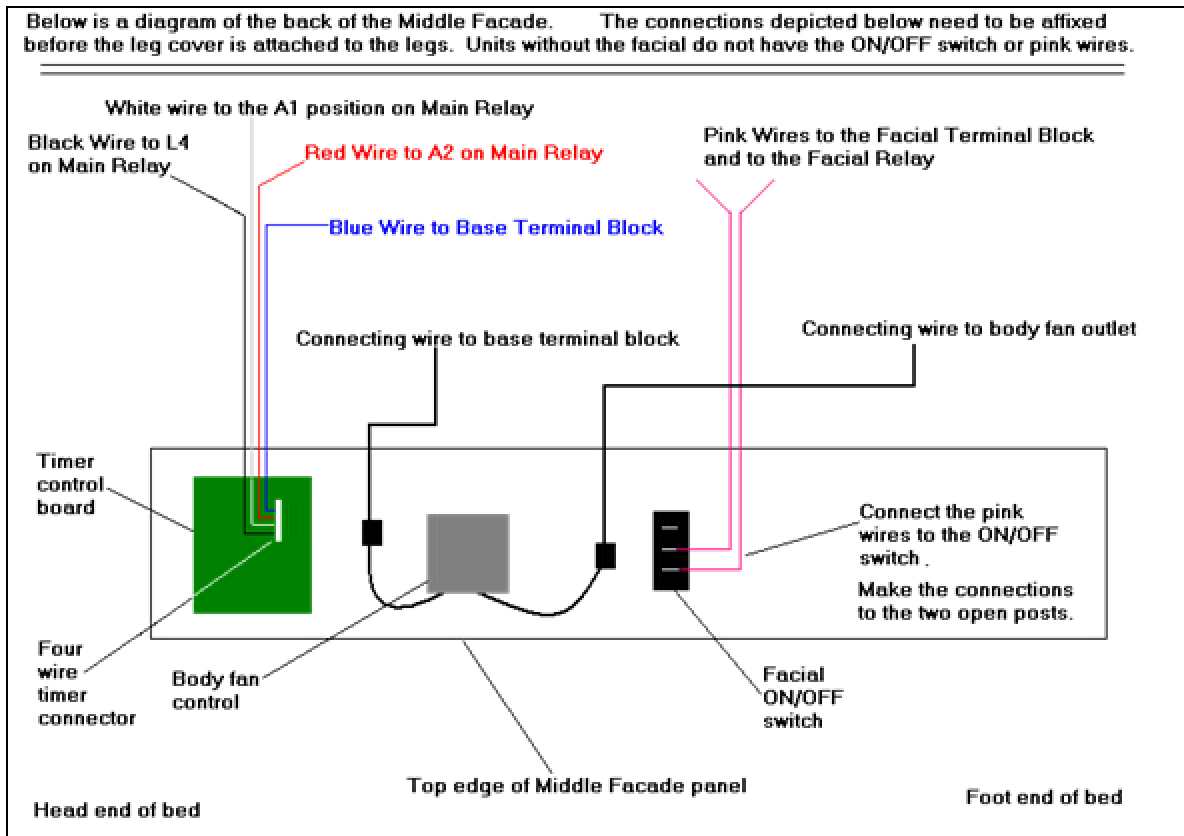

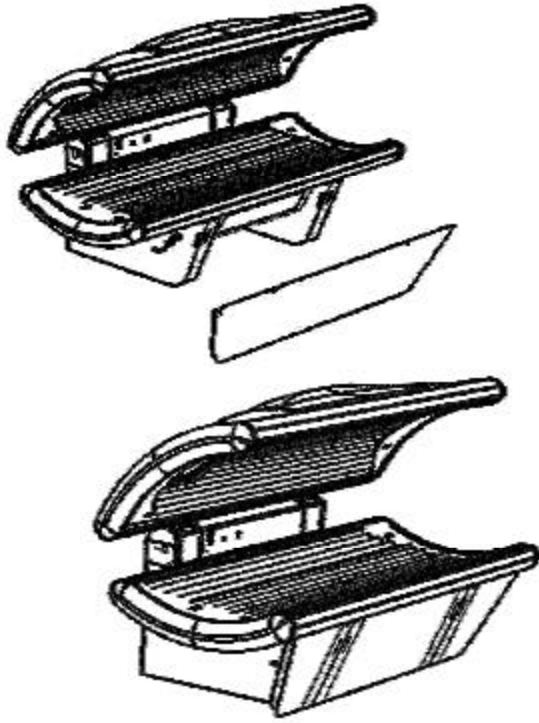

To install front façade, center the facade with the tanning system and position it in close proximity with the bottom of each leg. Align the clips on the bottom of the facade with the receptacles on each leg (one person can lift, install, and secure the “Front Façade” to the tanning system”).

## ACRYLIC REMOVAL & INSTALLATION

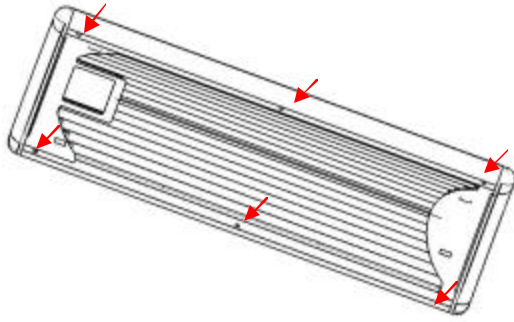

Quarter turn fasteners are used to secure the acrylic to the canopy. A standard screw driver should be used to remove each of the six  $\frac{1}{4}$  turn fasteners. The location of the  $\frac{1}{4}$  turn fasteners are indicated by the arrows on the illustration on the left. The acrylic should be supported while the fasteners are being removed to avoid damaging the acrylic and or avoiding personal injury. Once the fasteners are all removed the acrylic should slide out of its position and stored in a safe place while service is being performed.

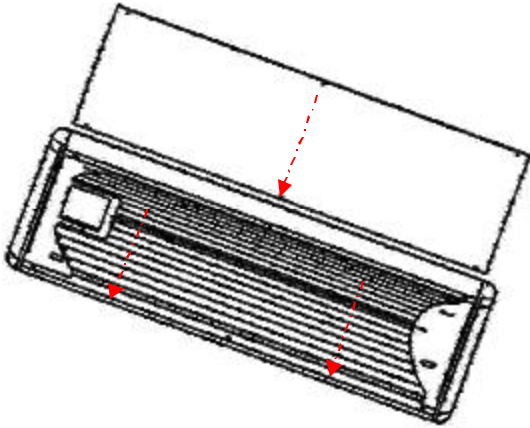

To assist with the installation process of the canopy acrylic, follow the steps listed below:

- Place the acrylic inside the track on the back of the canopy
- Install  $\frac{1}{4}$  turn screws in the center locations first, then in each end of the canopy.

## FACIAL ASSEMBLY

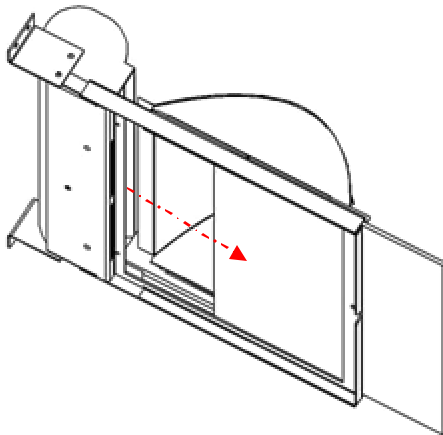

**Special CAUTION** must be exercised when lowering the facial assembly. Once the fastener used to secure the facial housing to the canopy is removed, the facial housing will pivot downward on an angle. The potential for the filter glass to slide out of its original position is present. To prevent the filter glass from falling out, breaking and or potentially causing personal injury, remove the facial filter glass during the service process.

## LAMP REMOVAL

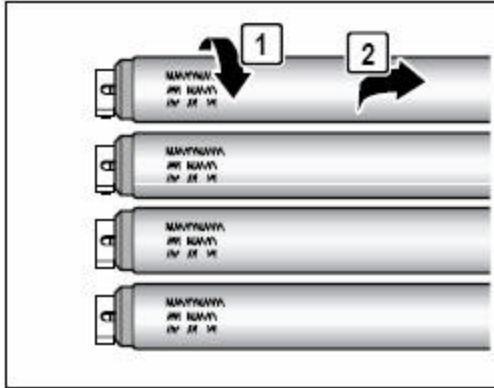

To remove lamps, rotate 90° and lift out.

## LAMP INSTALLATION

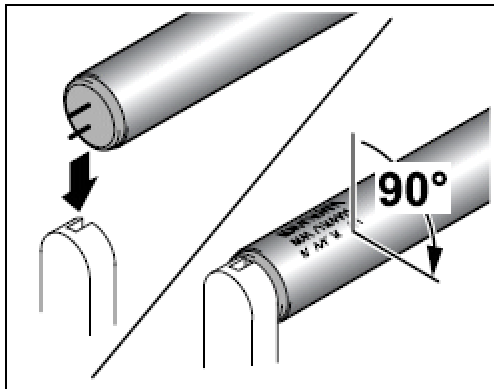

To install lamps, position pins inside lamp holder as illustrated and rotate 90°. Lamp etching should always be visible to tanner after installation.



# CANOPY (SERVICE PARTS EXPLOSION)

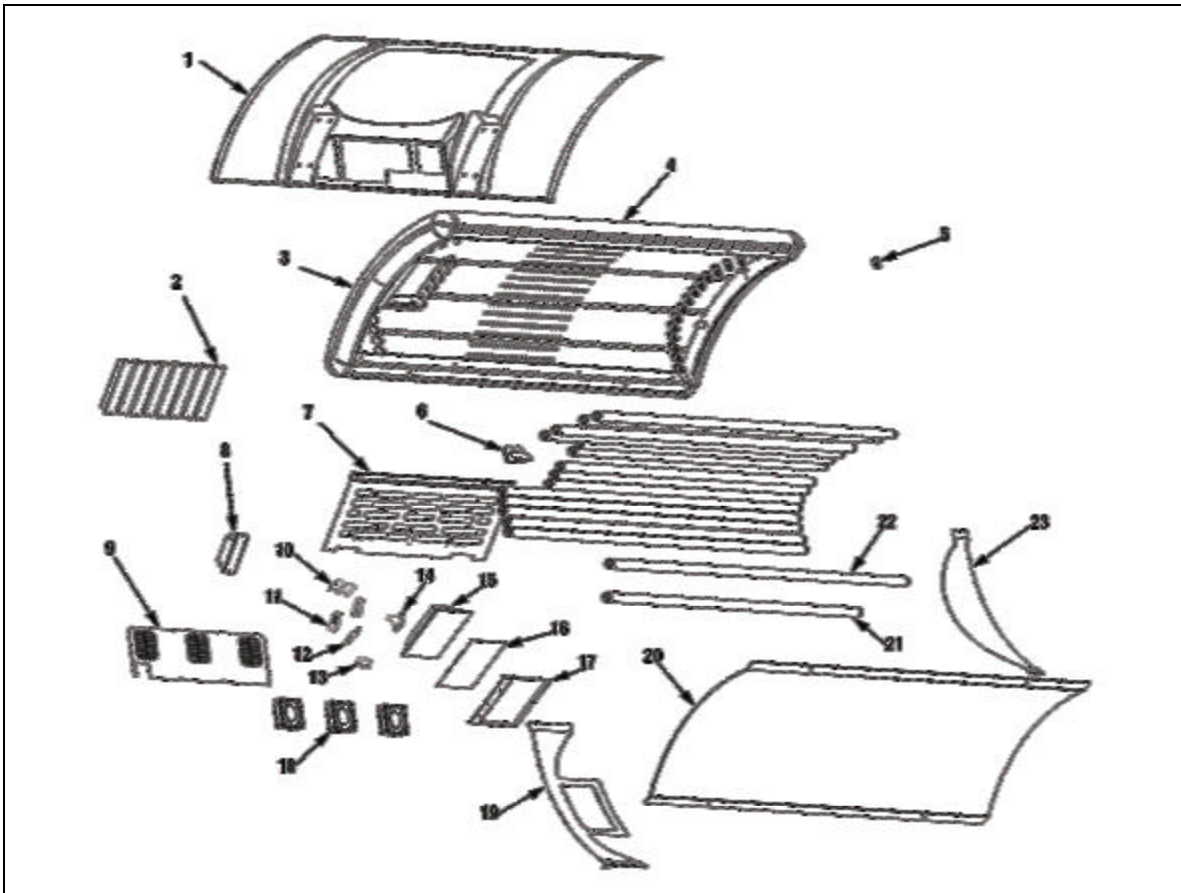

## CANOPY SERVICE PARTS

<b>NO.</b>	<b>PART NO.</b>	<b>DESCRIPTION</b>
1	0055005000	UPPER COVER
2	0031002482	BALLAST, ELECTRONIC SMART CELL
3	N/A	NOT A SERVICE ITEM
4	N/A	NOT A SERVICE ITEM
5	0000012321	LAMP HOLDER W/O STARTER (BLACK)
6	N/A	NOT A SERVICE ITEM
7	N/A	NOT A SERVICE ITEM
8	0031002030	BALLAST, 400 W
9	N/A	NOT A SERVICE ITEM
10	N/A	NOT A SERVICE ITEM
11	0000050408	LAMP HOLDER FACIAL CERAMIC
12	0000100723	HP PRESSURE LAMP (400W)
13	N/A	NOT A SERVICE ITEM
14	0000011716	TEMPERATURE FUSE 120°C
15	N/A	NOT A SERVICE ITEM
16	0000735044	HP FACIAL FILTER GLASS
17	N/A	NOT A SERVICE ITEM
18	0032002410	AXIAL FAN (105 CFM) 120V
19	N/A	NOT A SERVICE ITEM
20	0000550046	ACRYLIC, SUNDASH 32
21	0000012842	LAMP 59" (100 W)
22	0000012843	LAMP 71" (120 W)
23	N/A	NOT A SERVICE ITEM

## BASE (SERVICE PARTS EXPLOSION)

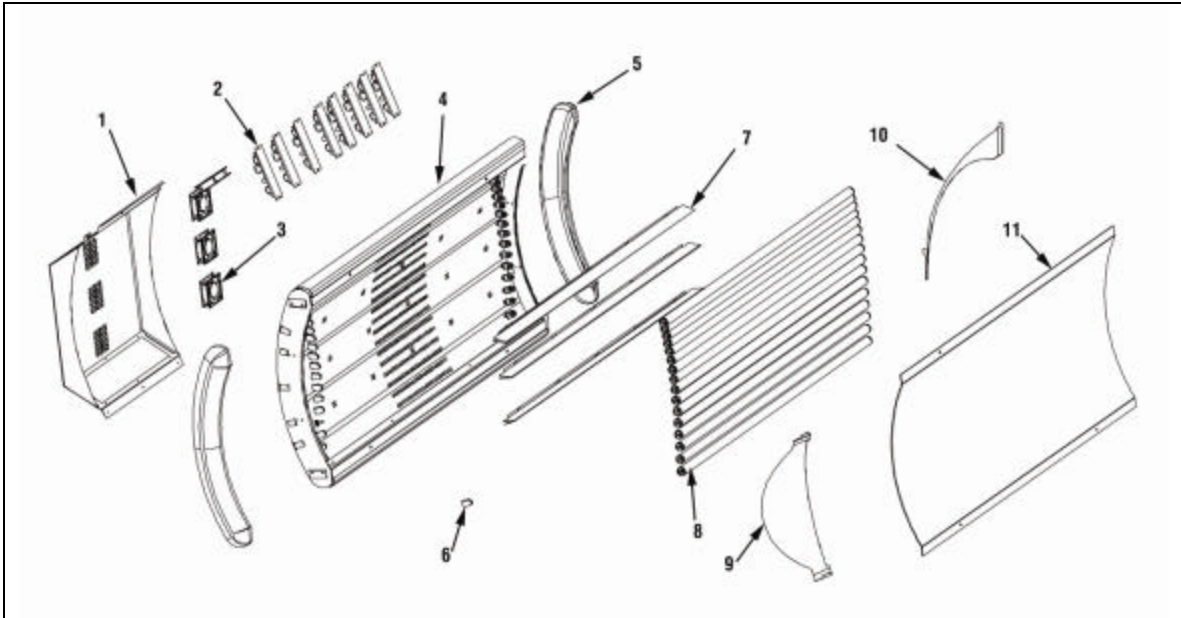

## BASE (SERVICE PARTS)

NO.	PART NO	DESCRIPTION
1	N/A	NOT A SERVICE ITEM
2	0031002482	BALLAST ELECTRONIC SMART CELL
3	0032002410	AXIAL FAN (105 CFM) 120 V
4	N/A	NOT A SERVICE ITEM
5	N/A	NOT A SERVICE ITEM
6	0000050408	LAMP HOLDER W/O STARTER (BLACK)
7	N/A	NOT A SERVICE ITEM
8	0000012843	LAMP 71" (120 W)
9	0055005026	LAMP HOLDER COVER (HEAD END)
10	0055005028	LAMP HOLDER COVER (FOOT END)

# LEG & MIDDLE FAÇADE (SERVICE PARTS EXPLOSION)

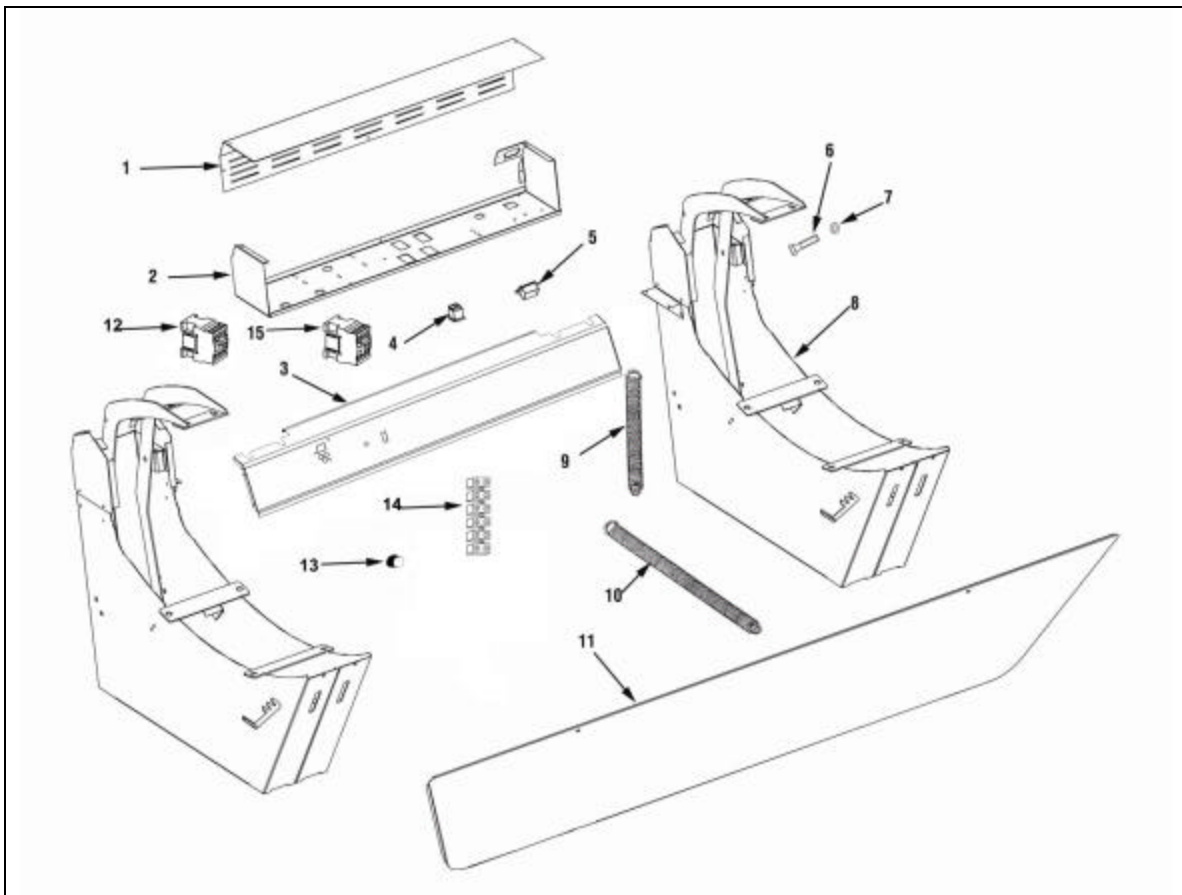

## LEG & MIDDLE FAÇADE (SERVICE PARTS)

<b>NO.</b>	<b>PART NO.</b>	<b>DESCRIPTION</b>
1	N/A	NOT A SERVICE ITEM
2	N/A	NOT A SERVICE ITEM
3	N/A	NOT A SERVICE ITEM
4	0030002684	AMP, RECEIPT 120V
5	0038002114	HOUR METER, DIGITAL
6	N/A	NOT A SERVICE ITEM
7	N/A	NOT A SERVICE ITEM
8	N/A	NOT A SERVICE ITEM
9	0055006126	SPRING 110#
10	0039002153	SPRING 55#
11	0055005100	FRONT COVER, WHITE
12	0035002293	RELAY, 25 AMP 120V
13	0055003540	KNOB BLACK (FAN RHEOSTAT CONTROL)
14	0037002682	TERMINAL BLOCK 16 POSITION
15	0035002209	RELAY, 9 AMP 120V

## ADDITIONAL SERVICE PARTS

	Description	Part Number
<b>Timer</b>		
	TIMER,ELO5	0038003001
<b>Label</b>		
	TIMER LABEL	0050005482
	LOGO LABEL	0050005451
<b>Button</b>		
	FACIAL ON/OFF SWITCH	0000011566
	RHEOSTAT	0032002252
<b>Igniter/Capacitor</b>		
	IGNITER, 100-400W FACIAL	0000010535
<b>Limit Switch</b>		
	MICRO LIMIT SWITCH	0036002605

## TIMER USER'S GUIDE

This tanning system is equipped with a digital timer that has the T-MAX<sup>®</sup> communication protocols built in. The timer will allow the tanning system to operate in stand-alone mode or be placed on a digital timer network. In addition the timer also supports wireless technology. An AP900 OEM wireless module will be required to place the tanning system on the wireless network. The timer also allows the tanning system to be compatible with most third-party controllers that support contact closure operational configurations.

### CONFIGURATION

#### *Setting Parameters*

- 1) Apply power to the Tanning System
- 2) Press and hold the **START/STOP** and **UP** buttons at the same time on the timer until the display changes and appears similar to illustration **A**. The keys should be kept pressed down for about 5-6 seconds. Release the buttons once the display changes.

#### ILLUSTRATION A

- 3) Press the **UP** or **DOWN** number that you want is parameters on page 2).

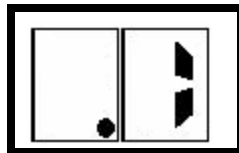

Button until the parameter displayed (see list of

4) To observe the current value of a parameter, press the **START/STOP** button.

The Display will show a number with a period in the lower center of the display. The numbers will be flashing. The number shown is the current value for that parameter (see illustration **A**).

For Lamp Hours, Session Counts, etc. the value displayed can be as high as 9999. To display this value, the timer will flash two numbers-three times, then two numbers-three times, pause, two numbers-three times, two numbers-three times, pause, etc. For example, if you are checking lamp hours (Parameter 6) and the display flashes the numbers 53 three times, then 14 three times, pauses then repeats, then the total lamp hours stored in the particular timer is 5314.

5) Press the **UP** or **DOWN** button to change the parameter to the desired value.

If you want to clear the value for that parameter, press the **UP** and **DOWN** buttons at the same time until the display changes and appears similar to illustration B.

#### ILLUSTRATION B

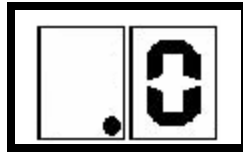



6) Press the **START/STOP** Button.

The display will show the parameter number you just changed and a solid period in the lower center of the display. Nothing will be flashing. You may now change another parameter by pressing the **UP** and **DOWN** buttons until the parameter you want displayed. Repeat Steps 2-4.

7) To exit the Parameter mode and make the timer available for the next session, press and hold both the **UP** and **DOWN** buttons until the period goes away. The display changes and appears similar to illustration C.

### ILLUSTRATION C



**Table 1 - Parameter Numbers for Observing and Changing Parameters.**

\* If Manual Lockout is enabled, the timer cannot operate as a stand-alone timer. In the event of a timer failure, this parameter cannot be enabled at the timer.

Parm #	Description	Max #	Default	Notes
1	Address	255	254	Station address of timer (each tanning system must have a unique address)
2	Beep Mode	1	0	Used for High Power beds. 0=Alarm only, 1=Alarm and Flip
3	Session Delay Time	5	0	Session delay after which time the tanning system will turn on automatically
4	Current Sense	1	0	For the Sentry™ Option. 0=Disabled, 1=Enabled.
5	Session Counts	65535	0	Total session counts (number of times the tanning systems has been turned on/off)
6	Lamp Hours	65535	0	Lamp hours for each bed.
7	Bed Hours	65535	0	Number of hours the tanning system has been operating.
8	Manual Session Counts	65535	0	Counts the number of sessions the timer has ran.
9	Clean Room	1	1	0 = Clean Room Disabled, 1 = Enabled
10*	Manual Lockout	1	0	0 = Stand Alone Enabled, 1 = Disabled
13	Cool Down Mode	10	0	0 = Disabled, 1-10=Enabled. Time delay in minutes allowing bed to cool.
15	Fixed Session Counts	65535	0	Counts number of sessions ran through the T-Max® 3A. This value cannot be changed at all. Used as point of reference.
17	Clean Clear	1	0	0 = Press and hold the Up button for 3-4 seconds to clear the clean room. 1 = Press and release the Up button to clear instantly
18	Redisplay	2	0	0 = After a session ends and the clean room is cleared, the timer will show a 0. 1 = After session ends and the clean room is cleared, the timer will show the last session time entered. 2-10 = After the session ends and the clean room is cleared, the max. time will show on the timer.
19	TPI Feature	1	0	0 = Configured to operate via Intellititan® or T-Max® controller. 1 = Configured to operate via a Third Part Controller (will accept contact closure)
20	External Speaker	1	0	0 = Speaker on timer, 1 = External Speaker will be used.
21	Auto bed shutoff	1	0	0 = tanning system will stay on when intercom is active. 1 = tanning system will shut off and go to pause mode if intercom is active.
22	Pause time	1	0	0 = When tanning system is paused, session time will continue to count down. 1 = When tanning system is paused, session time will not count down.

### Setting the Address

1) Press and hold the **START/STOP** and **UP** buttons until a .1 appears on the display (see illustration **A**). This should take about 5-6 seconds. Release the buttons.

2) Press and release the **START/STOP** button. A period, number (i.e. .3) or number, period number (i.e. 5.2) will be illuminated with the number flashing.

Pressing and holding the **UP** button will cause the display to count up.

Once the count reaches 100, the center period will flash rapidly. This is an indication that you are over 99. For example, if the display shows a 0.2 with the period flashing, this is address 102. The highest the display will count up is 254.

4) Press the **UP** or **DOWN** button until the desired address is displayed.

**Note:** Set each timer to a unique address. Do not set any address to 0 (unless you are using this timer as a master). Do not set any address over 100. If the period is flashing, you are over address 100.

5) Press the **START/STOP** button. A .1 will be displayed, with the 1 not flashing.

To exit Parameter Mode, press and hold the **UP** and **DOWN** buttons together until the period goes away.

### ***Setting Delay Time.***

1) Press and hold the **START/STOP** and **UP** buttons at the same time until a .1 appears on the display. This should take about 5-6 seconds. Release the buttons.

2) Press the **UP** button until a .3 is displayed.

3) Press and release the **START/STOP** button.

A number will appear on the display and be flashing. A period will be illuminated in the center of the display. This is the current delay time.

4) Press the **UP** or **DOWN** Button until the desired delay time is displayed.

The highest delay time that can be set on the timer is 10 minutes. If you want no delay time, set the display to 0. If you set the Delay Time to 0, the session time will start immediately after the **START/STOP** button is pressed.

5) Press the **START/STOP** button until a .3 is displayed. The 3 will not flash.

To exit Parameter Mode, press and hold the **UP** and **DOWN** buttons together until the period disappears.

### ***Starting a Session***

1) Press the **UP** or **DOWN** button on the timer until the session time is displayed. If the display shows a 0, and you want to count down from the maximum time, press the **DOWN** button.

2) Press and release the **START/STOP** button to start the session.

If a delay other than 0 is entered, the delay will count down. A period on the lower right corner of the display will flash rapidly. When the session starts, the period will flash at a once per second rate.

### ***Pausing a Session***

To pause the session, press the **START/STOP** button; the flashing period on the lower right corner of the display will stop flashing. The session time will continue to count down. The tanning system will turn off.

To resume the session, press the **START/STOP** button on the timer. The period on the lower right corner of the display will resume flashing.

### ***Canceling a Session.***

To cancel a session, press the **START/STOP** button to pause the session then press the **UP** button. The display will show a solitary 0.

### ***Interfacing with Digital Room Controllers***

- 1) Connect the timer to the tanning bed as described.
- 2) Set the address on each timer as described in “Setting the Address Section”.
- 3) Connect timers to the bed network. Connect the Digital Tanning System Controller to the closest timer. Refer to the Digital Tanning System Controller User’s Guide for operational instructions.

**Note:** The Digital Tanning System Controller or the software you are using if you are using a PC controls Delay.

### ***Clean Room***

Once the session time has elapsed, the display will show two solid periods only. This is an indication that the room needs to be cleaned. To clear the clean room indication, press and hold the **UP** button on the timer in the tanning room until the two periods disappear and a “0” appears. To disable the clean room feature, set parameter 9 to a 0.

# JK Products & Services

## Limited Warranty

JK Products & Service warrants its products to be free from defects in materials and workmanship under intended normal use as described in the unit's Operation and Instruction Manual, for a period of one (1) year from date of sale.

This Limited Warranty applies only to the original purchaser of the equipment through JK Products & Services or its authorized dealer or distributor, and is not transferable.

JK Products & Service obligations under this warranty are limited to repair or replacement of any defective part without charge for that part to the original purchaser, with the following exceptions:

A. Fluorescent lamps are warranted against defects for a period of thirty (30) days from date of sale.

B. Only parts obtained through JK Products & Service, its authorized dealers or distributors may be used. Transportation costs for parts shipped to the consumer and the return of defective parts to JK Products & Service are not included.

C. Labor will be furnished without charge for ninety (90) days from date of purchase only. All labor and related charges must be authorized by JK Products & Service prior to start of repairs, and must coincide with JK Products & Service established rates and time allotment policy.

D. Acrylic: Refer to Manufacturer's Acrylic Warranty Policy.

It is imperative that the original customer completes and returns the enclosed warranty card within 10 days after purchase to insure valid registration and coverage for potential claims.

If the warranty card is not registered, proof of purchase from JK Products & Service or its authorized dealer or distributor will be required prior to any consideration on warranty claims. This could result in service delays.

This warranty is extended to the individual or legal entity, whose name appears on the warranty registration card filed with JK Products & Service or whose name appears on the original sale document and may not be transferred to any other individual or legal entity.

This warranty does not apply to any failure of the product, or any parts of the product due to alterations, modifications, misuse, abuse, accident, improper maintenance, improper installation, acts of God or if the serial number on the product has been removed, altered or defaced. Adequate packaging must be used for returned goods to prevent freight damage.

**THERE ARE NO WARRANTIES WHICH EXTEND BEYOND THE DESCRIPTION ON THE FACE HEREOF. THERE IS NO EXPRESS OR IMPLIED WARRANTY OF FITNESS OR MERCHANTABILITY.**

**THE REMEDIES PROVIDED IN THIS LIMITED WARRANTY ARE THE EXCLUSIVE REMEDIES PROVIDED TO THE PURCHASER BY JK PRODUCTS & SERVICE AND ARE PROVIDED IN SUBSTITUTION OF ALL OTHER REMEDIES - CONSEQUENTIAL AND INCIDENTAL DAMAGES ARE EXCLUDED.**

No person, firm or corporation is authorized to obligate JK Products & Service for any liability in connection with the sale or use of these goods.

# Limited Acrylic Warranty

JK Products & Service warrants its acrylic sheets to be free from defects in material and workmanship, under intended normal use, for a period of one (1) year from date of sale of the tanning bed. Due to the tanning lotions, cosmetics, disinfectant and improper cleaners used on tanning surfaces that cannot be controlled by JK Products & Service, after the first thirty (30) days of warranty period. Acrylic will be subject to a prorated cost to the consumer on breakage.

JK Products & Service obligations do not include transportation charges on replacement acrylic.

JK Products & Service assumes no liability for the cost of removing defective sheets or installing replacement sheets, nor for damage to persons or property.

To make a claim, contact an authorized dealer or distributor of JK Products & Services or JK Products & Service, Service Department with the model number, the serial number, and the date of purchase of the bed in which the acrylic will be used.

**THERE ARE NO WARRANTIES WHICH EXTEND BEYOND THE DESCRIPTION ON THE FACE HEREOF. THERE IS NO EXPRESS OR IMPLIED WARRANTY OF FITNESS OR MERCHANTABILITY.**

**THE REMEDIES PROVIDED IN THIS LIMITED WARRANTY ARE THE EXCLUSIVE REMEDIES PROVIDED TO THE PURCHASER BY JK PRODUCTS & SERVICE AND ARE PROVIDED IN SUBSTITUTION OF ALL OTHER REMEDIES - CONSEQUENTIAL AND INCIDENTAL DAMAGES ARE EXCLUDED.**

**JK Products & Service  
1 Walter Kratz Drive  
Jonesboro, Arkansas 72401  
1-800-445-0624**

# Warranty Claims Policy & Procedures

## 1. When to file a Warranty Claim:

In the event that your tanning system is not functioning properly under intended normal use as described in the unit's Operation and Assembly Manual, you may then have established cause to file a Warranty Claim.

NOTE: Both the tanning system and legal registered owner must meet the criteria established under JK Products & Service Limited Warranty as described in this manual before any Warranty Claim will be considered.

## 2. Where to call to place a Warranty Claim:

JK Products & Service is supported nationwide by an extensive dealer/distributor network through whom the majority of our units are sold. These dealers/distributors are required by contract to stock sufficient parts to meet the various warranty and nonwarranty needs of their customers.

Therefore, in order for you to properly file a Warranty Claim, you must locate the name and phone number of the dealer/distributor through whom you purchased your unit. Normally this information can be easily located either on your paid invoice or other proof of purchase documentation that you received when taking delivery of the unit.

Next, notify the dealer/distributor of the serial number, model number and date unit was purchased. This will initiate the Warranty Claim process.

Upon determination of the problem, your dealer/distributor can then supply you with the part(s) and proper instructions to return your unit to working order.

Each dealer/distributor has their own internal procedure for handling Warranty Claims and credits.

**NOTE: JK Products & Service, the manufacturer, does not involve itself in the direct handling of a Warranty Claim except where mitigating circumstances apply and where required by law.**